

LEE SAFETY POWDER SCALE INSTRUCTIONS

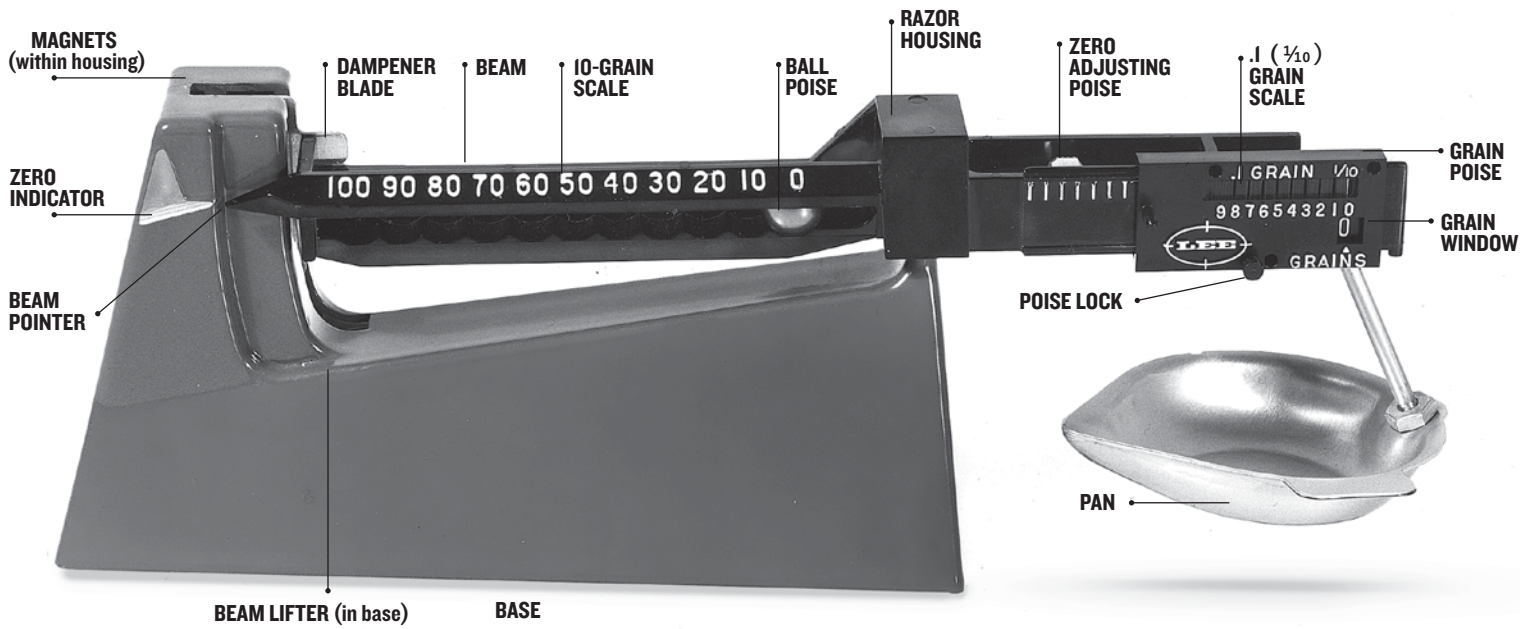

The Lee Guarantee

Lee Precision products are guaranteed not to wear out or break from normal use for two full years or they will be repaired or replaced at no charge if returned to the factory. Any Lee product of current manufacture regardless of age or condition will be reconditioned to new, including a new guarantee, if returned to the factory with payment equal to half the current factory list price.

SA2056

SCALE PARTS CANNOT BE PURCHASED SEPARATELY.

REPAIRS MUST BE DONE AT THE FACTORY AS PART CHANGES REQUIRE CALIBRATION.

SET UP

- 1 Place scale base on flat level surface
- 2 Set both poises to zero and lock the grain poise by pushing the poise lock in. Be sure the .1 (1/10) grain is ZERO.
- 3 Place beam onto the base and hang the pan from beam. Be sure beam swings freely.
- 4 Turn the zero adjusting poise to align the beam pointer to the zero indicator on the base. This should always be done before use or if the scale has been moved or bumped.

MAGNETIC DAMPENING

The Lee Safety Scale has magnetic dampening to rapidly slow the beam movement without adding friction. It is not excessively dampened to ensure maximum sensitivity.

USING THE SCALE FOR REPEATED CHARGES

Correctly position both poises and lock the grain poise with poise lock. Double check to be sure they are set correctly. Pour the charge into the pan until the beam starts to move. The approach-to-weight feature will lift the beam as you near the correct charge. This serves to alert you that only a little more powder be added to balance the scale.

LEE

LEE PRECISION, INC. 4275 Hwy. U Hartford WI 53027
www.leeprecision.com

PRINTED IN USA. © 1987 LEE PRECISION, INC.

USING THE SCALE TO WEIGH AN UNKNOWN CHARGE

Start with the grain poise at 10 grains (poise to the left). Move the ball to the first notch that causes the beam to drop. Slide the grain poise to balance the beam. You'll find it easier to make fine adjustments by watching the .1 (1/10) grain pointer. When nearly balanced, move only .1 (1/10) grain at a time.

MAINTENANCE

There is no maintenance needed nor possible by the user. Keep your scale clean and free of dust. The balance edge is a specially made, stainless steel razor blade—don't touch it as you will be cut. The scale beam is made from a stable, heat-resistant phenolic. It's tough, but will break if abused. Should it be damaged, don't try to fix it yourself. Return it to the factory for repair. All repairs are free for the first two years. See guarantee above.

The weight of the paper (under average conditions) outlined by the squares below demonstrates the degree of smallness of .1 (1/10) and 1 grain units.

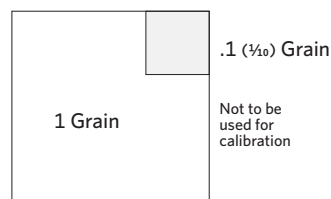

CONVERSION FACTORS FOR GRAMS METRIC & GRAINS AVOIRDUPOIS

GRAMS X 15.432 = GRAINS

GRAINS X .0648 = GRAMS

LEE SAFETY POWDER SCALE

You have purchased the best scale made for weighing gunpowder. The poise notches are over $\frac{1}{4}$ " apart to insure fast, accurate setting with no chance of mis-notching. An actual razor edge forms the pivot for the greatest sensitivity. The scale capacity is 110 grains, far more than needed for ordinary powder charges. This scale need be correct to one part in 1100 for $.1$ ($\frac{1}{10}$) grain precision. Other brands of scales that have a capacity of 510 grains must be accurate to one part in 5100 just to equal the accuracy of the Lee Scale. That would be the same as a 300-pound bathroom scale that would weigh to less than one ounce. While this sort of accuracy is not impossible, it does cost considerably more and makes such a scale easier to be misread or subject to damage that is not easily detected. Should you find that there is significant difference in the weight of an object weighed on a Lee Scale and a scale of another brand, we would suggest that, for the reasons given above, you consider the correct weight to be that from the Lee Safety Scale.

The Lee Safety Scale beam is made from phenolic. This is commonly used for handles on pots and pans and the tough surface on tables and desks. It is tough and hard; like glass, can be broken but not bent. This assures you that it could never be overstressed and give wrong, possibly dangerous readings. Even if you are careful with your equipment, there's always the chance the cat could knock it off the shelf. If it's a Lee Safety Scale you'll know that if it isn't broken, it will give correct weights.

BALL POISE

Every notch this ball is moved equals 10 grains. The ball poise is a stainless steel non-magnetic ball. Never remove this ball or replace it with a "ball bearing." This ball is specially made to extreme, uniform tolerances from one "heat" of metal to assure uniform and exact weight.

GRAIN POISE

Slowly slide the grain poise and you will notice white indicator marks move across the $.1$ ($\frac{1}{10}$) grain window. Read $.1$ ($\frac{1}{10}$) grains under the center mark of the 3 visible marks **NOTE** When reading zero or 9, the 3rd mark will be at the opposite end of the scale. See examples 2 and 3.

If only 2 lines are visible (plus a tiny amount on either side), you are then exactly halfway between graduations and reading to $.05$ ($\frac{1}{20}$) grain. See example 4 below. There is never any need for this kind of accuracy in reloading.

POISE LOCK

The poise can be locked at a setting by pushing in on the poise lock. To unlock the poise—pull out, or push from the back side. The lock is only used when you preset the scale for weighing multiple charges or setup.

